



INSTALLATION INSTRUCTIONS

MAGNETIC BREAKERLESS CONVERSION KIT FOR MALLORY DISTRIBUTORS

IMPORTANT

This conversion kit must be used with an ignition ballast resistor (or loom resistance wire) to prevent module failure. If your vehicle is not equipped with a ballast resistor or loom resistance wire, Mallory Ballast Resistor (Part No. 700) may be used.

APPLICATIONS

NOTE: *These kits do not work with vacuum advance distributors.*

Part No. 564-R Mallory 8 cylinder point distributors (automotive and marine) which use a standard stack cap (Part No. 209 or 209D) and rotate clockwise (RH)

Part No. 564-L Mallory 8 cylinder point distributors (automotive and marine) which use a standard stack cap (Part No. 209 or 209D) and rotate clockwise (LH)

NOTE: *These kits will only work in distributors which use a "YH" advance mechanism. Look for an "H" at the end of the part number located on a tag on the distributor bowl.*

PARTS INCLUDE IN THIS KIT:

- 1 Sleeve/Plate Assembly
- 1 Magnetic Module
- 1 Rotor
- 1 Bag Hardware

INSTALLATION

Step 1

Remove the cap and rotor, then remove the condenser.

Step 2

Remove the plastic insulators (see Figure 1).

Step 3

Loosen the 2 nuts that hold the cap clips/brackets in place (see Figure 1). **NOTE: To loosen the nuts on a marine distributor, the aluminum pins in the brackets may need to be cut in two and removed. Replacement pins are provided.**

Step 4

Remove the point plate assembly by lifting it out of the housing (see Figure 1).

Step 5

See Figure 2.

Remove the advance springs. Remove the two E-clips. Remove the advance weights and bushings.

Step 6

Lift the sleeve and advance plate up and off the distributor shaft.

NOTE: *Between the distributor shaft drive plate and the advance plate is a thrust washer. Sometimes the thrust washer sticks to the bottom of the advance plate during removal of the sleeve and advance plate. Make sure you install the thrust washer on the distributor shaft drive plate. A replacement thrust washer is provided if your thrust washer needs replacement.*

Step 7

Lubricate the distributor shaft and the top and bottom of the thrust washer. A light coating of moly lube/grease or similar lubricant is acceptable. Install the reluctor sleeve and advance plate on the distributor shaft. Install the felt pad into the top hole of the reluctor sleeve.

Step 8

Install the advance weights and bushings. Install the two E-clips. Install the advance springs.

Step 9

See Figure 3.

Install the module assembly into the housing. Make sure that the cut-out in the plate is directly below the hole in the housing where the wires will exit.

Step 10

Tighten the two nuts that hold the cap clips/brackets in place. This also secures the module plate.

Marine Distributors Only

Replace the cap clips using the new aluminum pins provided.

Step 11

Install the wire grommet. Lubricate the wires with light oil. Run the wires through the grommet and out of the distributor housing.

Step 12

Put the three wires into the female connector:
GREEN WIRE in hole #1
BROWN WIRE in hole #2
RED WIRE in hole #3

FIGURE 1

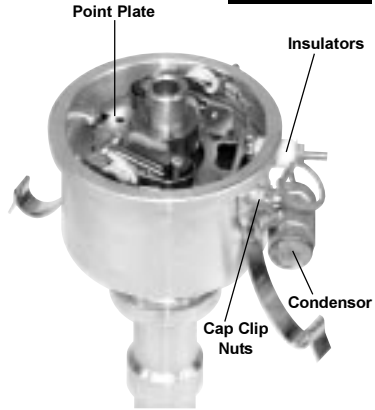

Plug the female connector into the distributor wire harness. See Figure 3.

Step 13

Connect the three wires of the wire harness to the correct locations as indicated in Figures 5 and 6.

Step 14

Set the pickup gap (see Figure 4).

Step 15

If the distributor was removed from the engine, reinstall. Install the cap, rotor, and plug wires. Static time the engine. Start the engine and recheck the timing.

FIGURE 2 YH ADVANCE

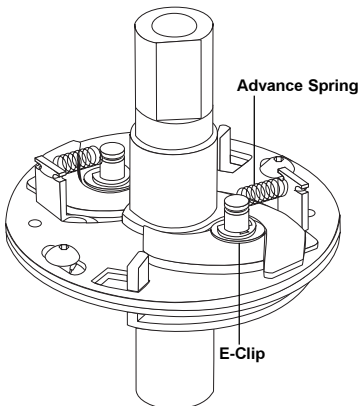

LEFT HAND ROTATION

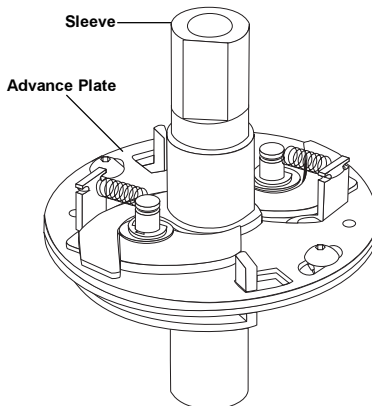

RIGHT HAND ROTATION

FIGURE 3



FIGURE 4

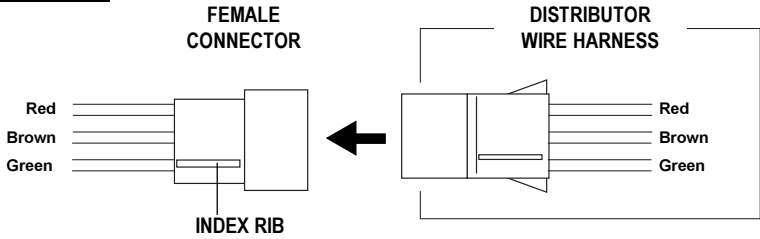

FIGURE 5

TO SET MAGNETIC PICKUP GAP:

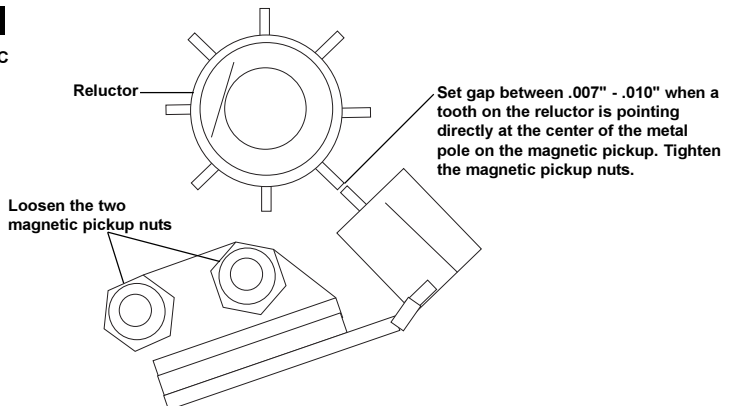
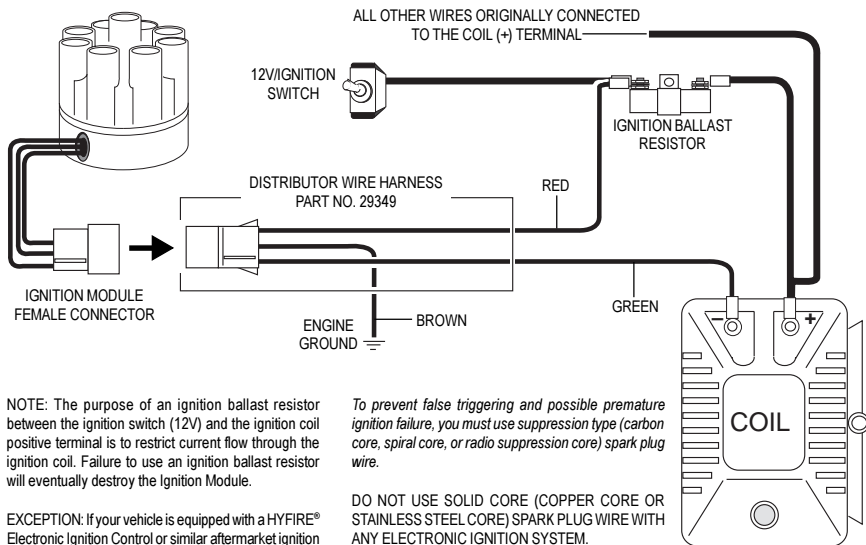

FIGURE 6 WIRING WITH BALLAST RESISTOR



NOTE: The purpose of an ignition ballast resistor between the ignition switch (12V) and the ignition coil positive terminal is to restrict current flow through the ignition coil. Failure to use an ignition ballast resistor will eventually destroy the Ignition Module.

To prevent false triggering and possible premature ignition failure, you must use suppression type (carbon core, spiral core, or radio suppression core) spark plug wire.

EXCEPTION: If your vehicle is equipped with a HYFIRE® Electronic Ignition Control or similar aftermarket ignition control, use the wiring procedures stated in the instructions included with the ignition control

DO NOT USE SOLID CORE (COPPER CORE OR STAINLESS STEEL CORE) SPARK PLUG WIRE WITH ANY ELECTRONIC IGNITION SYSTEM.

FIGURE 7 WIRING WITH LOOM RESISTANCE WIRE

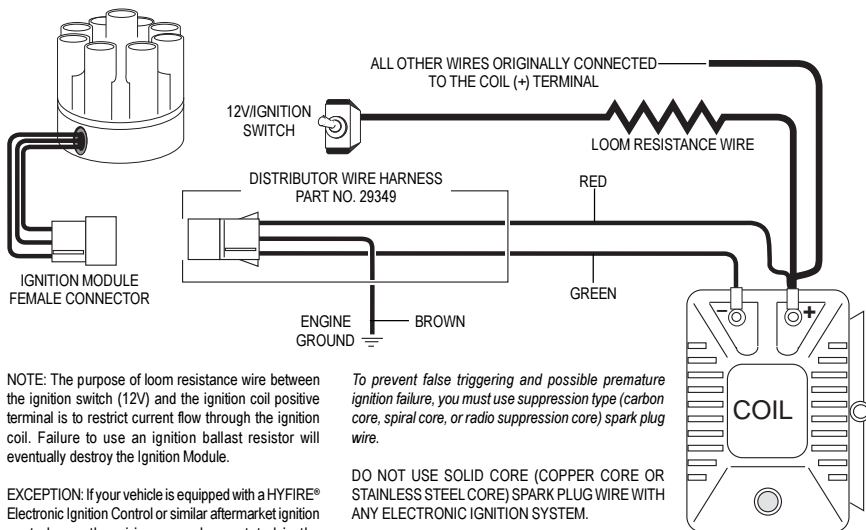

NOTE: The purpose of loom resistance wire between the ignition switch (12V) and the ignition coil positive terminal is to restrict current flow through the ignition coil. Failure to use an ignition ballast resistor will eventually destroy the Ignition Module.

To prevent false triggering and possible premature ignition failure, you must use suppression type (carbon core, spiral core, or radio suppression core) spark plug wire.

EXCEPTION: If your vehicle is equipped with a HYFIRE® Electronic Ignition Control or similar aftermarket ignition control, use the wiring procedures stated in the instructions included with the ignition control.

DO NOT USE SOLID CORE (COPPER CORE OR STAINLESS STEEL CORE) SPARK PLUG WIRE WITH ANY ELECTRONIC IGNITION SYSTEM.



MALLORY IS A DIVISION OF THE MR. GASKET PERFORMANCE GROUP
 550 MALLORY WAY, CARSON CITY, NV 89701
 (775) 882-6600 FAX (775) 887-4326
 www.mrgasket.com

FORM #1321
 REV. B (8/99)
 MADE IN U.S.A.
 PRINTED IN U.S.A.