



# INSTALLATION INSTRUCTIONS

## WINDOW RPM ACTIVATED SWITCH

### PART NO. 646

#### Parts Included in this kit:

- 1 RPM Activated Switch Part No. 646
- 1 "U" shaped crimp-on wire terminal
- 1 #6 x 1/4" sheet metal screw
- 2 Velcro™ strips

### CONTENTS

General Information .....	1
Mounting Procedure .....	1
Wiring Procedure .....	1
How to Set the Window RPM Switch .....	2
Wiring Diagrams for the RPM Activated Switch	
Connecting to a HYFIRE® IV .....	2
Connecting to a HYFIRE® VII .....	3
Connecting to relays with a HYFIRE® VII .....	3
Connecting to a Timing Retard .....	4
Connecting to a Timing Control .....	4
Connecting to a Light .....	4
Connecting to an Electric (Shifter) Solenoid .....	5
Connecting to a Nitrous System .....	6
Connecting to a Nitrous System and Timing Retard .....	6
Shifnoid Warning .....	7

### GENERAL INFORMATION

The Mallory 646 Window RPM Switch is an RPM switch that is triggered from the tach terminal available on most aftermarket performance ignitions. It will not only activate at a particular RPM, but can also be set to deactivate at a second, higher, RPM. It can be used on 4-12 cylinder engines.

**NOTE: The Mallory 646 CANNOT be triggered from points or electronic distributor. It must be triggered from a tach output terminal.**

The 646 features two independent sets of switch contacts that switch other devices on or off when the selected RPM is reached. These contacts switch a maximum current of 5 amps. To switch more than 5 amps, you must use the RPM Activated Switch output to drive a high current relay, such as a horn or headlight (see illustrations).

**NOTE: The switch contacts are NOT connected electrically. This allows you to turn one circuit on and another off at the same RPM.**

### MOUNTING PROCEDURE

#### Step 1

Disconnect the battery (-) cable to cut power to the system.

#### Step 2

Mount the unit in an area away from hot engine components or extreme heat, such as exhaust manifolds, and away from moving parts, such as fans, belts, and linkages.

#### Step 3

Mount the unit using supplied Velcro™ strips.

### WIRING PROCEDURE

#### Step 1

Connect the BLACK WIRE to engine or chassis ground. You can use the supplied "U" shaped terminal and #6 x 1/4" sheet metal screws to make this connection. If you are connecting the RPM Activated Switch to an aftermarket ignition system such as a Mallory HYFIRE®, use the same grounding location that the ignition uses. See Figures 2-4, pages 2-3.

#### Step 2

Connect the RED WIRE to a 12-volt power supply, such as the ignition switch. You can use the same wire that provides power for your ignition as long as a ballast resistor is not wired in series with it. **NOTE: Do NOT connect the RED WIRE to the coil (+) terminal. Connect it to the wire coming directly from the ignition switch. If your vehicle is equipped with loom resistance wire, you must provide an alternate power connection to the red wire.**

#### Step 3

The GREEN WIRE must be connected to the ignition system tach output.

- When using a Mallory ignition system, connect the GREEN WIRE to the TACH terminal. See Figures 2-4, pages 2 and 3.
- When using an aftermarket ignition with a TACH output, connect the GREEN WIRE to the TACH terminal. Check manufacturer's ignition instructions to find this location.
- Other aftermarket ignitions – Connect the GREEN WIRE to the tachometer lead terminal. Check manufacturer's ignition instructions to find this location.

#### Step 4

To connect a device that you want to switch ON at the RPM setting you've selected, such as a shift light, connect one ORANGE WIRE to the device and the other ORANGE WIRE to a 12-volt power supply. Connect the remaining wire from the device to a ground. See Figure 5, page 4.

#### Step 5

To connect a device that you want to switch OFF at the RPM setting you've selected, such as a nitrous solenoid, connect one PURPLE WIRE to the device and the other PURPLE WIRE to a 12-volt power supply. Connect the remaining wire from the device to a ground.

#### Step 6

Secure all wires to prevent contact with extreme heat, sharp objects, or moving devices, such as fans, belts, and linkages.

#### Step 7

Recheck all wires and connections to ensure that they are correct before applying power.

#### Step 8

Reconnect the battery (-) terminal cable. Start engine and check operation of the RPM Activated Switch.

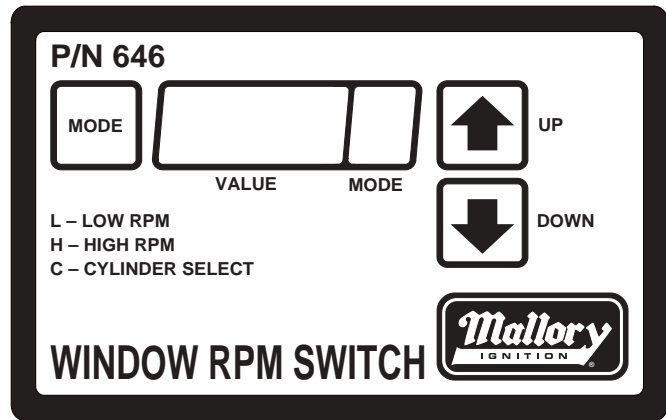
## HOW TO SET THE WINDOW RPM SWITCH

**FIGURE 2**

On the front panel there are three buttons and an LED display. The "MODE" button cycles through the low RPM setting, the high RPM setting, and the cylinder number select. The "UP" and "DOWN" buttons move the RPM in 100 RPM increments in either of the RPM modes, and select 3-12 in the cylinder select mode.

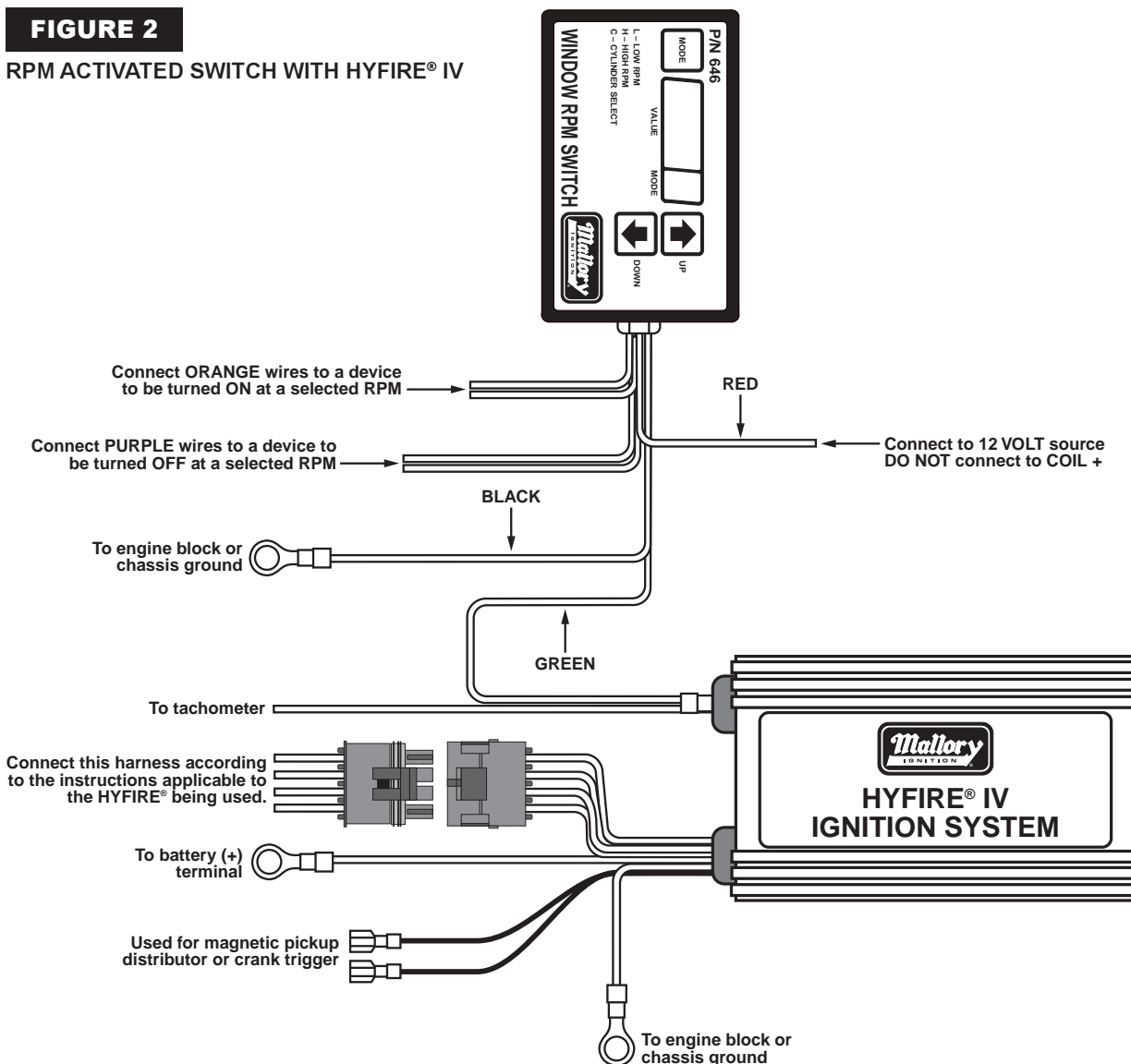
The RPM range is 1000 to 16000 in 100 RPM increments. The high setting (H) must be at least 200 RPM higher than the low (L) setting for the switch to operate properly. The display shows RPM in hundreds (for example, "76" would be 7600 RPM).

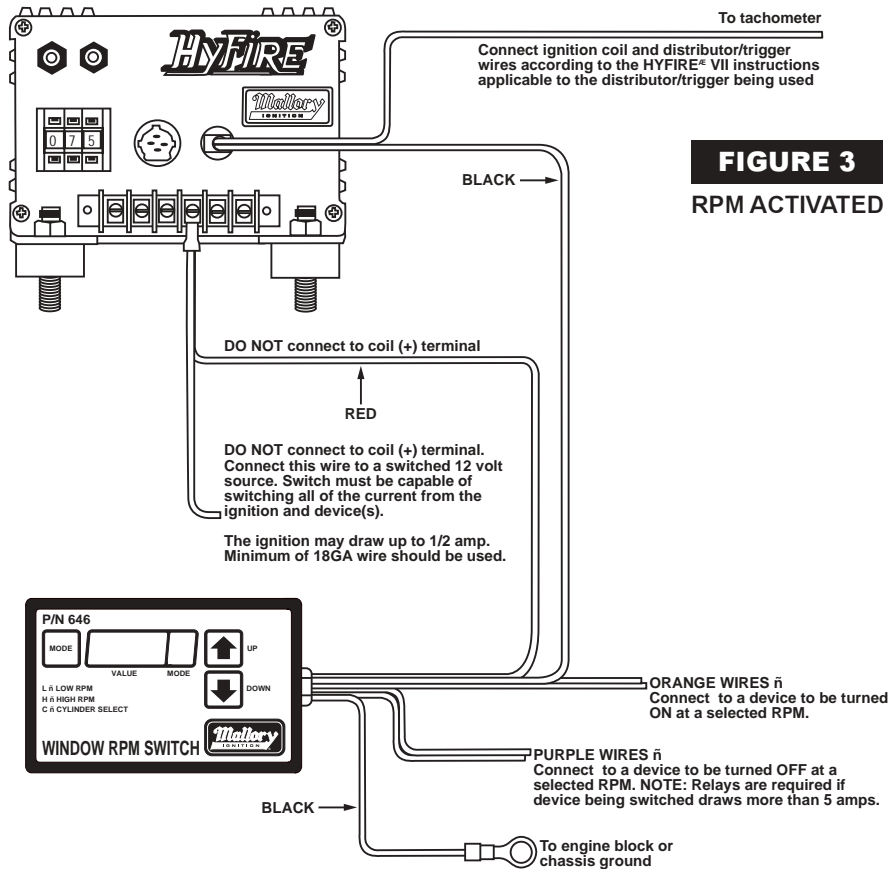
Set the cylinder select mode to the number of cylinders your engine has (4-cycle only).



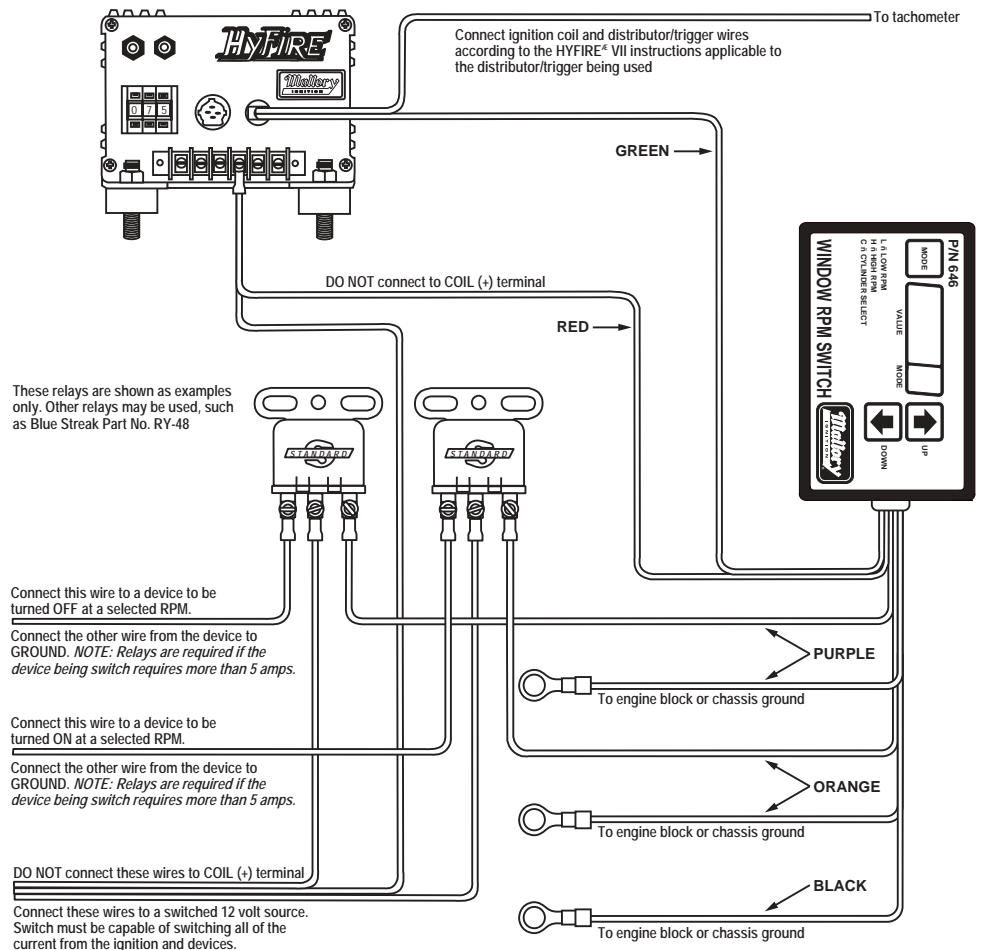
**FIGURE 2**

RPM ACTIVATED SWITCH WITH HYFIRE® IV

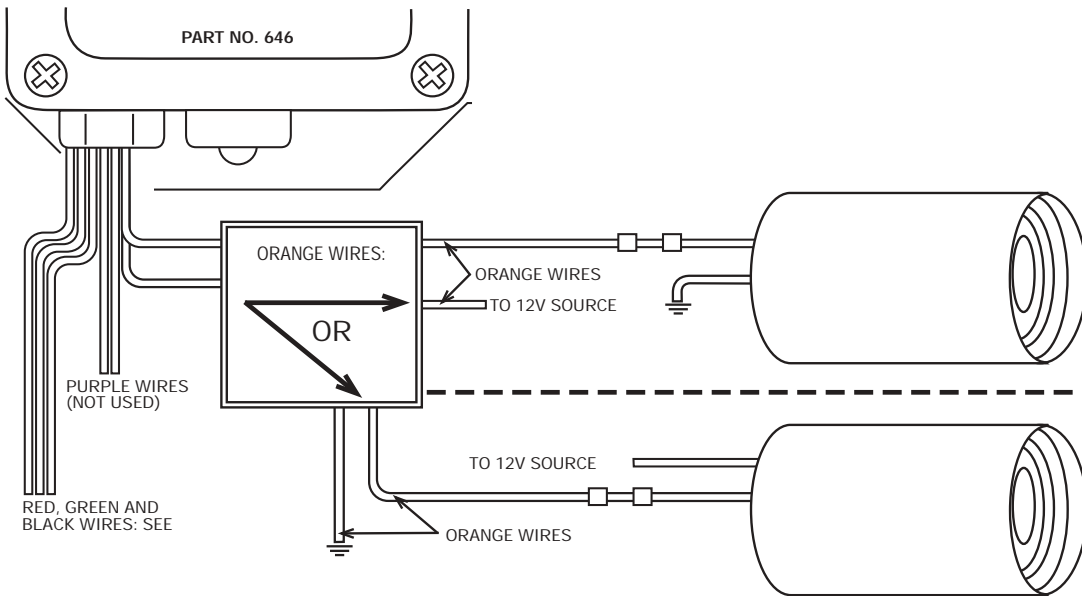
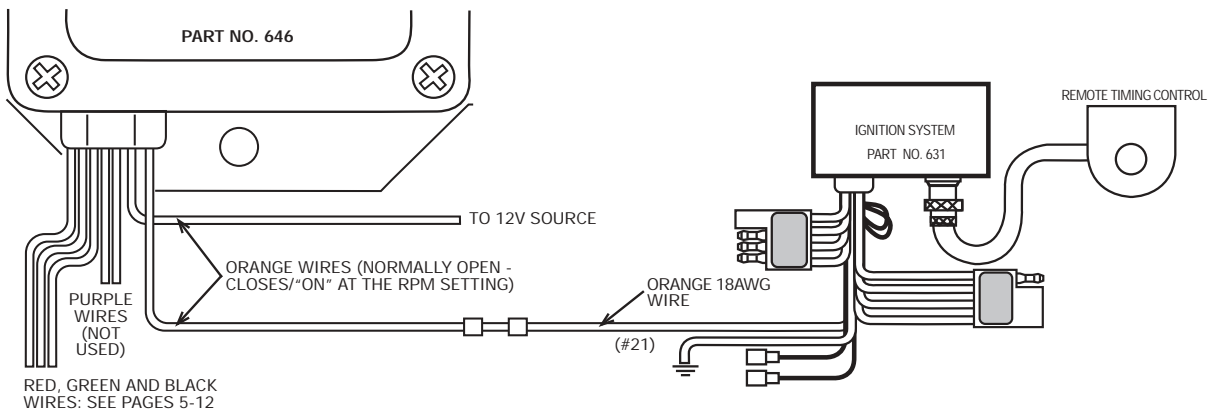
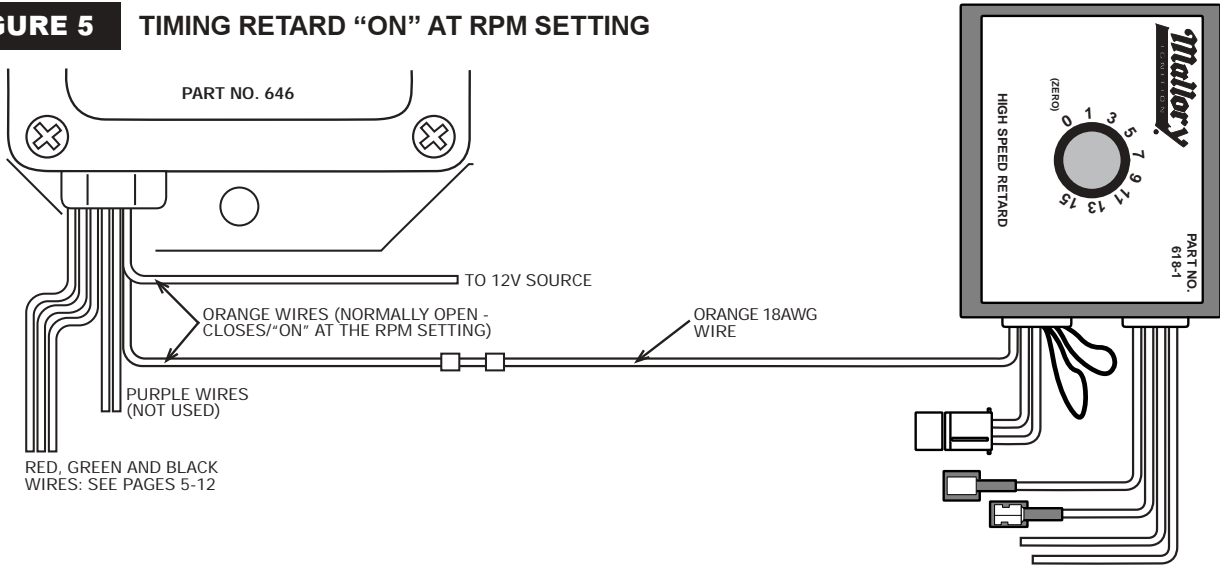




**FIGURE 4**  
RPM ACTIVATED SWITCH AND RELAYS WITH HYFIRE® VII

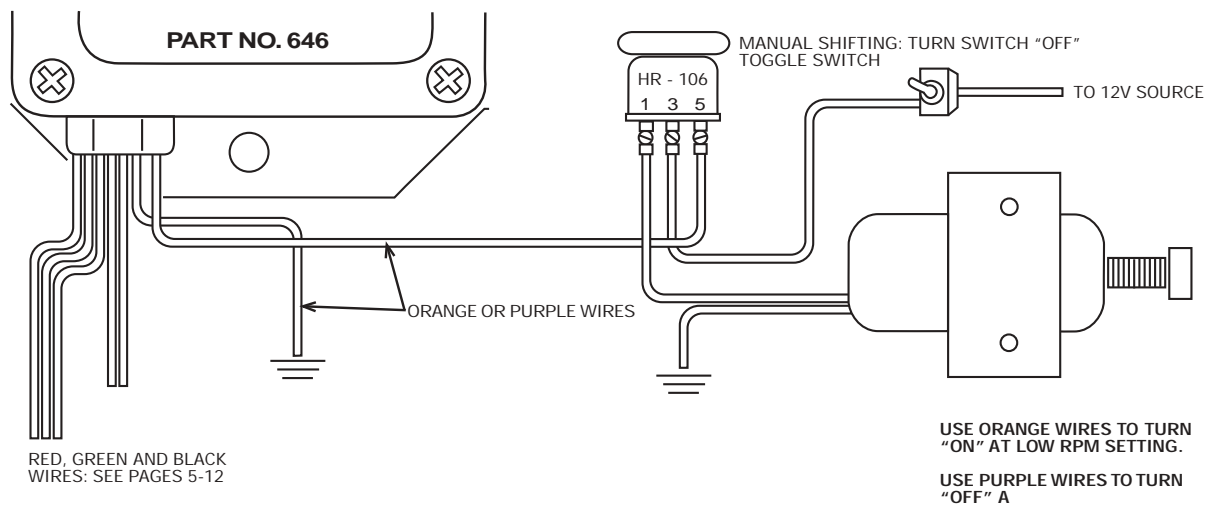
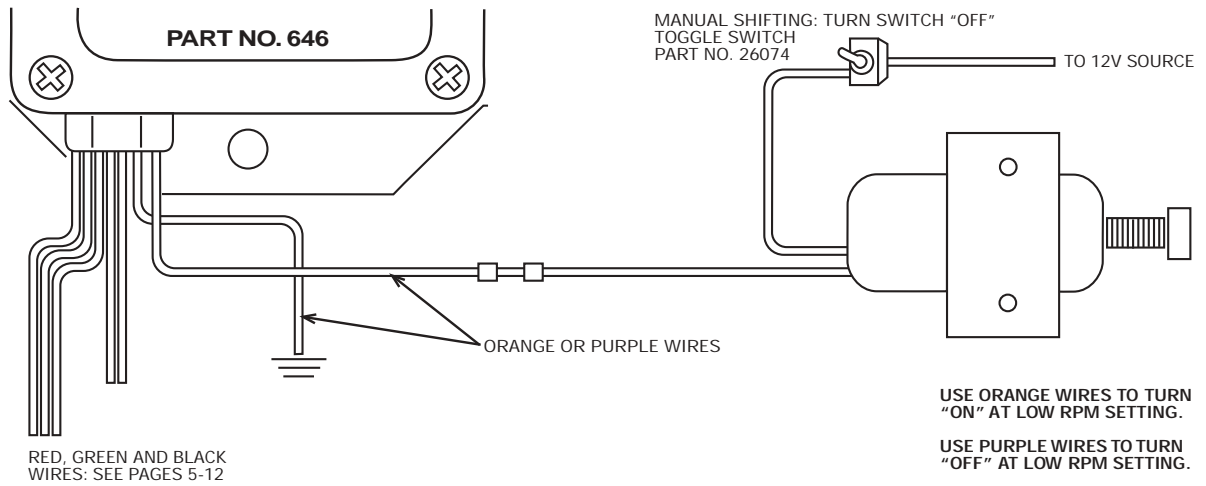
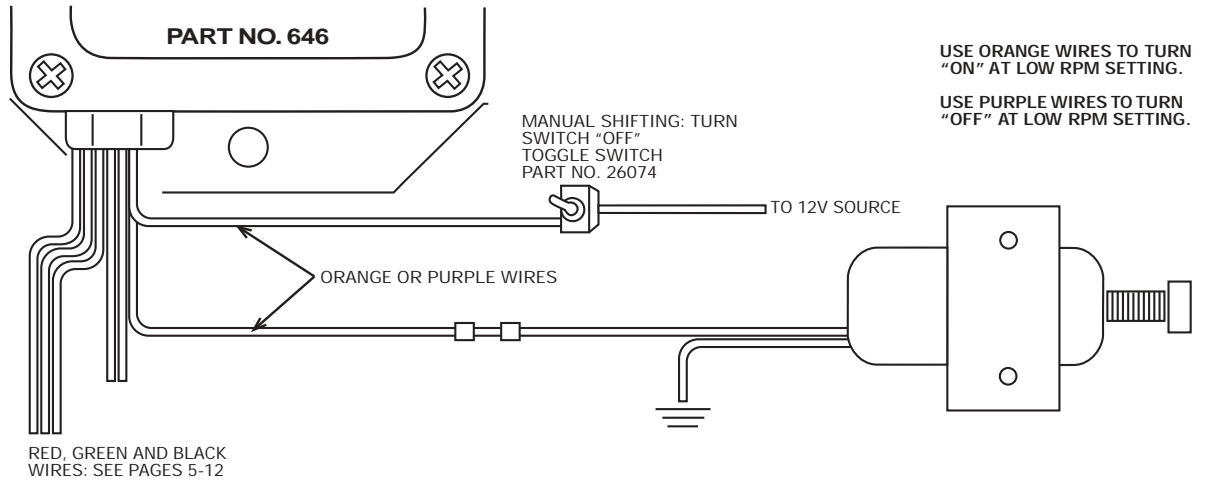


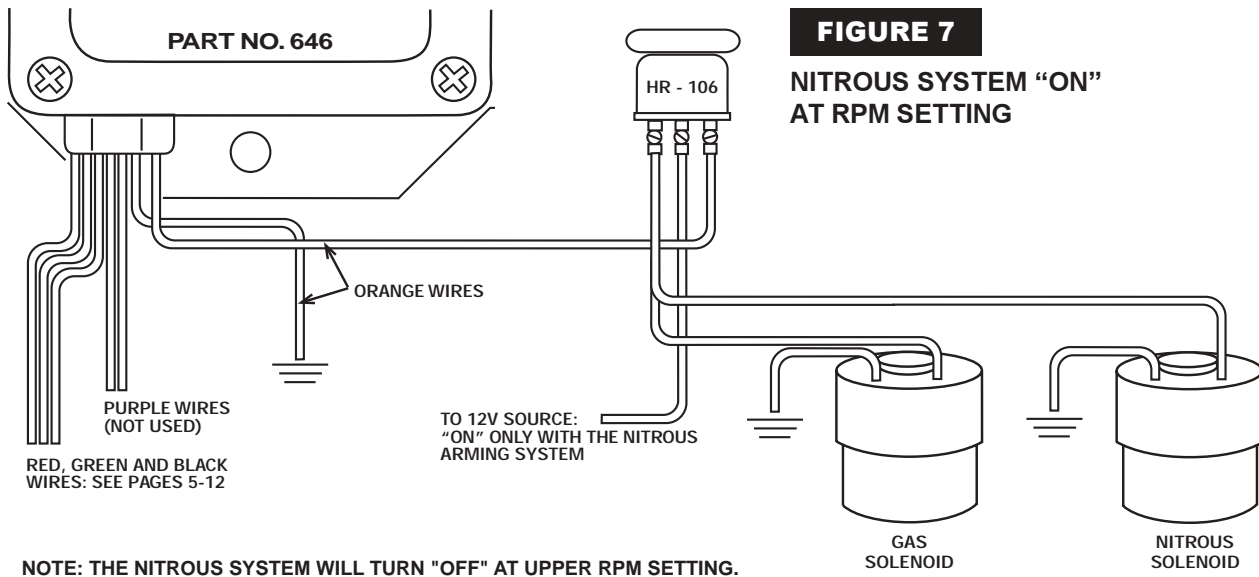
**FIGURE 5** TIMING RETARD "ON" AT RPM SETTING



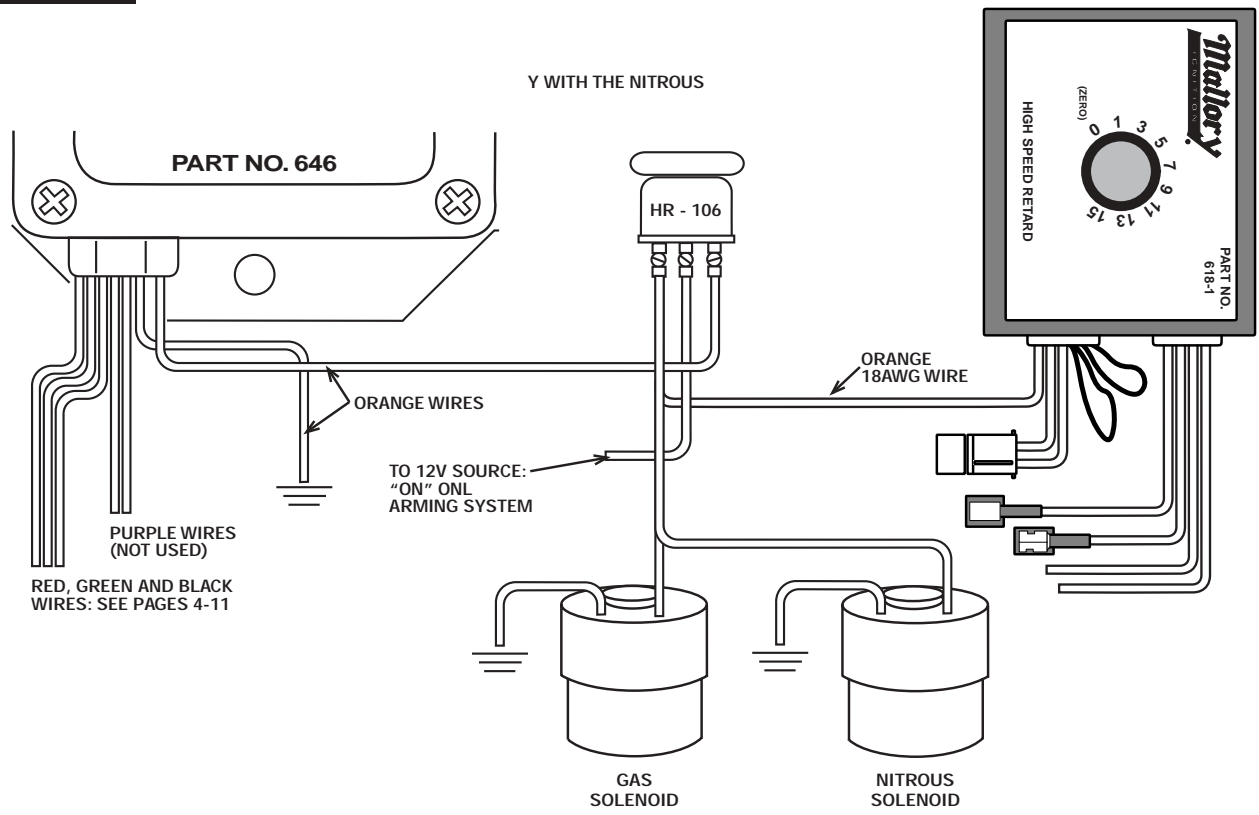
NOTE: TO TURN LIGHTS "OFF" AT RPM SETTING - EXCHANGE THE ORANGE WIRES AND THE PURPLE WIRES.

**FIGURE 6 ELECTRIC (SHIFTER) SOLENOID**



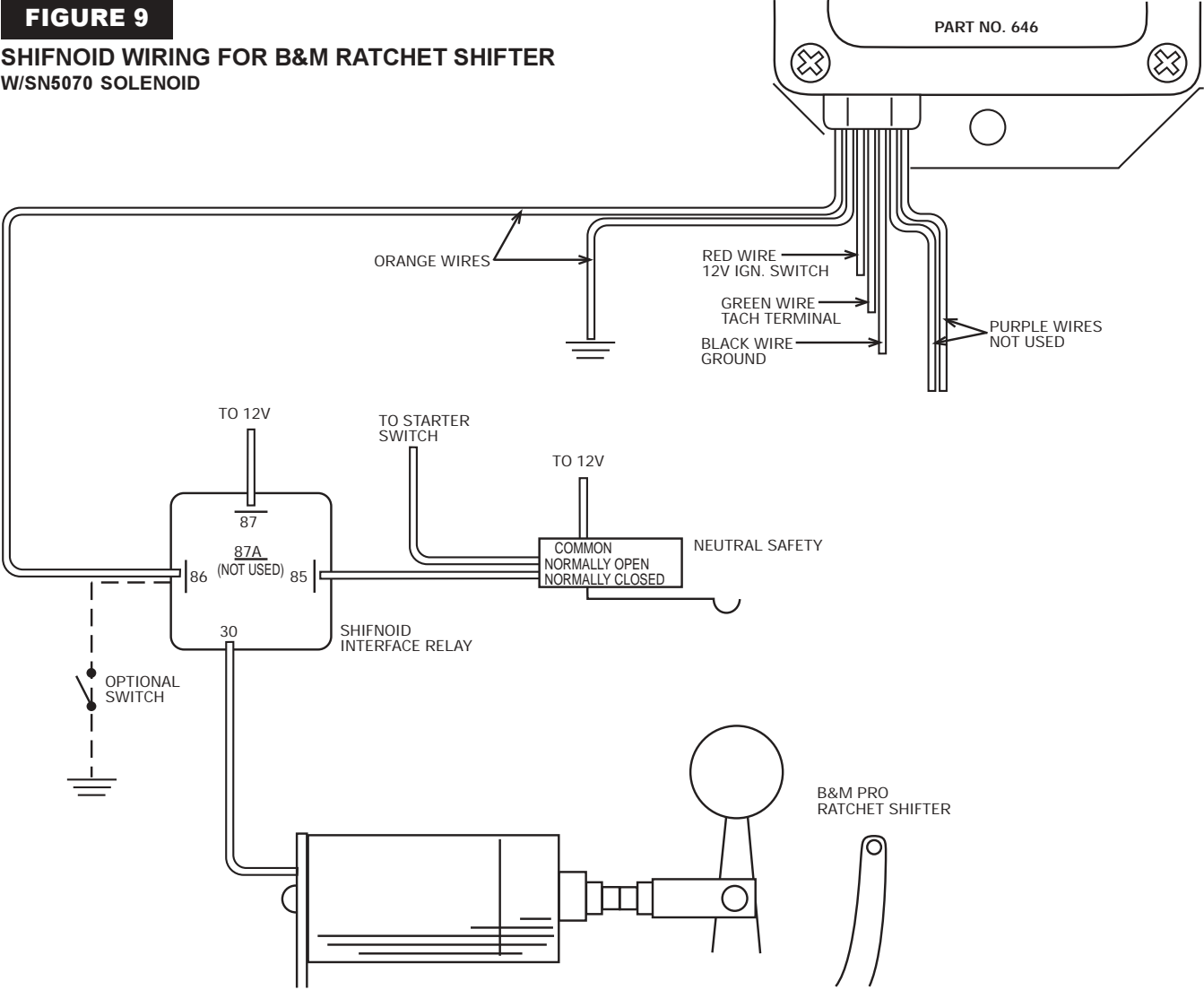


**FIGURE 8** NITROUS SYSTEM AND TIMING RETARD "ON" AT RPM SETTING



**FIGURE 9**

**SHIFNOID WIRING FOR B&M RATCHET SHIFTER  
W/SN5070 SOLENOID**





MALLORY IS A DIVISION OF THE MR. GASKET PERFORMANCE GROUP  
550 MALLORY WAY, CARSON CITY, NEVADA 89701  
(775) 882-6600 FAX (775) 887-4326  
[www.mrgasket.com](http://www.mrgasket.com)

FORM 1008  
(REV. A) 01/02  
Made in U.S.A.  
Printed in U.S.A.