



FIRE STORM™

FORM 69100S/R

MALLORY FIRESTORM CD MULTI COIL HARDWARE INSTALLATION - PN 69100S / 69100R

To ensure you are using the most current instruction sheet, please visit www.malloryfirestorm.com.

CAUTION!

The SMART coil secondary outputs extremely high voltage. Make sure to avoid contact with the tower and or plug wire during key on, and while the vehicle is running or serious injury can result. Always make sure the battery is disconnected during installation and maintenance.

PARTS INCLUDED:

FireStorm Ignition Module
Main Harness
Coil Harness
8 pin Flying lead adapter harness
10 pin accessory harness (69100R only. 69100S optional)
Software Installation CD
Hardware kit

GENERAL INFORMATION

Battery

This Ignition Control Module operates on any negative ground, 12 volt electrical system with a distributor. It will also work with 16 volt batteries. If your application does not use an alternator, allow at least 15 amp/hour for every half hour of operation. If you crank the engine with the same battery or other accessories, such as an electric fuel or water pump, increase the amp/hour rating.

Coils

For optimum performance with your Ignition Control Module, use matching coil such as MALLORY Firestorm (140053 Bottom Tower or 140054 Side Tower).

Using the correct spark plug and heat range is important for optimum performance. Because there are so many variables to consider, we suggest starting with your engine manufacturer's spark plug recommendation. From there, you can experiment with small changes in plug gap and heat range to obtain the best performance from your engine. We also recommend non-resistor spark plugs.

Spark Plug Wires

High quality, spark plug wires with a resistance rating of no less than 500 ohms/ft, and proper routing are essential to the operation of the Firestorm Ignition Control Module. This type of wire provides a good path for the spark to follow while minimizing electromagnetic interference (EMI). **NOTE: Do not use solid core spark plug wires with this Ignition Control.**

Routing

Wires should be routed away from sharp edges, moving objects, and heat sources. For added protection MALLORY offers PRO SLEEVE (P/N836). Pro Sleeve is a glass woven, silicone coated protective sleeve that slides over your plug wires and helps reduce damage from heat and sharp objects.

Welding

To avoid any damage to the Ignition Control Module when welding

on the vehicle, disconnect the main positive (red) and negative (black) power cables of the Ignition Control Module. It is also a good idea to disconnect the tachometer ground wire as well.

MISCELLANEOUS INFORMATION

Sealing

Do not attempt to seal the Ignition Control Module. All of the circuits receive a conformal coating of sealant that protects the electronics from moisture. Sealing the Ignition will not allow any moisture that seeps in through the grommets to drain and may result in corrosion.

WIRING

Wire Length

All of the wires of the Ignition Control Module may be shortened as long as quality connectors are used or soldered in place. To lengthen the wires, use one size larger gauge wire (12 gauge for power leads, 16 gauge for all others). Use the proper connectors to terminate all wires. All connections must be soldered and sealed.

Grounds

A poor ground connection can cause many frustrating problems. When a wire is specified to go to ground, connect it to the chassis. Always connect a ground strap between the engine and chassis. Connect any ground wires including shield ground wires to a clean, paint-free metal surface.

Module Installation:

Ensure that the ignition key is off and disconnect the battery. Determine a suitable mounting location for the Firestorm module such as a fenderwell or firewall, to minimize exposure to heat, moisture and moving parts. Make sure all wires reach their connections. The Firestorm Ignition Control Module can be mounted in any position, but should not be mounted in an enclosed area such as the glovebox. Once a suitable mounting location is determined, hold the module in place and mark the location of the mounting holes. Use a 1/8" drill bit to drill the holes and use the supplied self tapping screws to mount the box.

Wiring connections:

Refer to the wiring illustrations below for your specific application. Connect the 12v switched ignition lead (labeled 12V SW) to a 12v source that is live during crank and run. Consult your factory wiring diagrams and verify with a test light. The Firestorm module must have 12v ignition power during cranking or the vehicle will not start. Connect the VBAT lead directly to the battery positive terminal and the PWR GND lead directly to the battery negative terminal. Connect the 10 way coil out harness to the main coil harness.

The main coil harness is designed to connect to OEM GM Odd/Even coil harnesses, or Mallory Even 77640 and Odd 77641 coil harnesses. (The GM or Mallory SMART coil harnesses are a direct plug in)

Trigger Inputs

Connect the CAM/CRANK sensor adapter harness (LS2-LS9 78655M) to 8 PIN Ignition (CAM/CRANK) Connector at the Module.

WIRE FUNCTIONS

Power Leads

Vbat - Red 14 ga - battery power- connect directly to clean battery

positive terminal

Power Ground - Black 14 ga - battery ground - connect directly to clean battery negative terminal
12v Sw Ign - Red/white 12 volt switched ignition power - connect to a 12v ignition source that has power during start and cranking

Coil Connections

10 way multi coil out - Connect to the included main coil harness - connect harness leads marked even and odd to their respective engine coil harnesses.

Shield ground - Connect to a good, clean chassis ground to minimize EMI noise. Due to the high energy output of the Firestorm module, it is very important that shield ground wires are well grounded to ensure proper operation.

Other Connections:

3 way MAP connector - connect to optional MAP sensor kit to expand the tuning resolution of the Firestorm module based on engine load. The Firestorm module defaults to an ignition curve that references

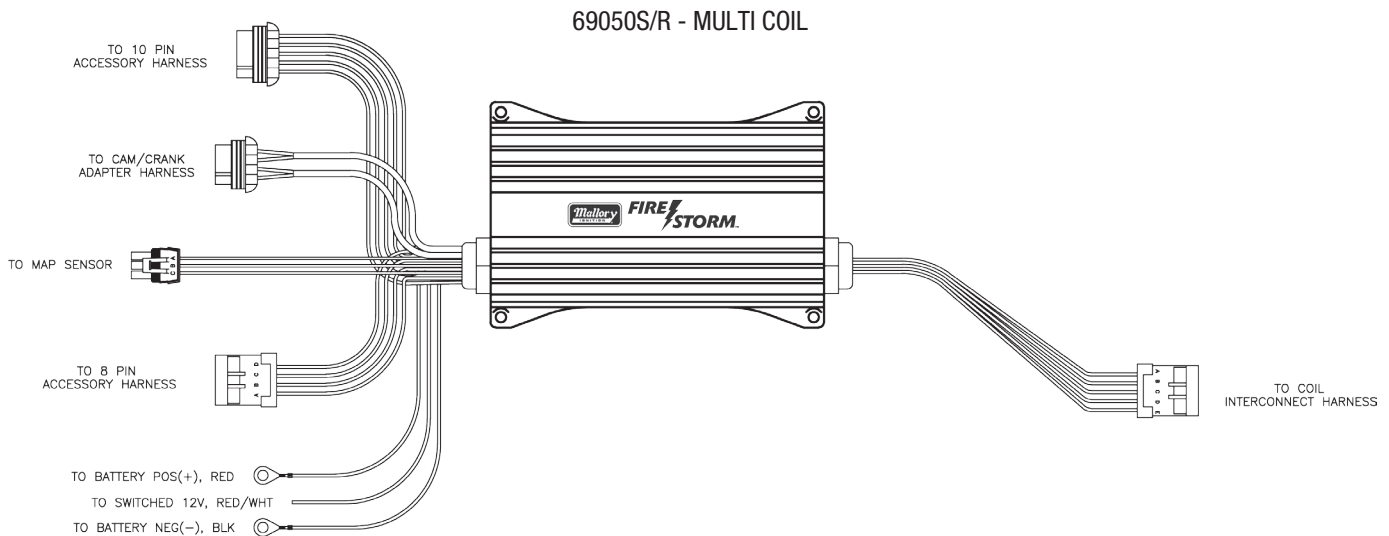

engine RPM only if a MAP sensor is not connected.

Accessory connectors:

There are 2 accessory connectors (8 and 10 pin) that can be used to enable and control optional functions in the Firestorm ignition module. Below is a listing of their individual functions and basic operating description. Refer to the ACCESSORY HARNESS LAYOUT on page 5 or the software guide for information on configuring the Firestorm software for proper operation of these functions.

Shift light - ground output to illuminate an external shift light. The Firestorm module will ground this wire at the engine RPM you set in the Mallory SparkMap software

MIL - Malfunction indicator light - ground output to illuminate a MIL light when a trouble code has been set. The trouble code can be read with the Mallory SparkMap software.

2 Step - a 12v input on this line activates the 2 step rev limiter based on settings in the Mallory SparkMap software.

3 Step - a 12v input on this line activates the 3 step rev limiter based on settings in the Mallory SparkMap software.

Signal Ground - provides ground circuit for sensor inputs such as ECT, IAT and TPS.

VSS - Vehicle Speed Sensor input.

ECT - Engine Coolant Temperature signal input

IAT - Intake Air Temperature signal input

Fan 1 - ground output to control a single electric fan relay based on temperature settings in the Mallory SparkMap software.

Fan 2 - ground output to control a secondary electric fan relay based on temperature settings in the Mallory SparkMap software.

PTS - not used in multi coil applications

Tach - Engine speed output for an external tachometer or as an RPM input to another module (i.e. Gen 7/Thruster ECM in fuel only mode)

TPS - Throttle Position Sensor signal input

UEGO - Universal Exhaust Gas Oxygen (wideband O2) sensor input

Data (0 to 5 Volt from Wide Band Module).
Or DATA LOG Trigger - Ground input to trigger internal data-logging for applications where data-logging without a laptop is required.

Aux 2 - Ground output. Use to ground a relay based on settings in the Mallory SparkMap software output configuration screen

FP / Aux 3 - Ground output to control a fuel pump relay, or other auxiliary relay based on settings in the Mallory SparkMap software output configuration screen

Switched 12v Out - 12v output at key on to provide power to other modules.

ROUTING WIRES

Route all wires away from heat sources, sharp edges, and moving objects. Route the trigger wires separate from the other wires and spark plug wires. If possible, route them along a ground plane, such as the block or firewall, which creates an electrical shield. The magnetic pickup wires should be routed separately and twisted together to help reduce extraneous interference. For best results use Shielded Ground Cable.

CAUTION!

The SMART coil secondary outputs extremely high voltage. Make sure to avoid contact with the tower and or plug wire during key on, and while the vehicle is running or serious injury can result. Always make sure the battery is disconnected during installation and maintenance.

PRESTART CHECKLIST

- The small red/white wire is connected to a switched 12 volt source, such as the ignition key. This wire must be hot in crank and run positions.
- Power leads are connected directly to the battery positive and negative terminals.
- If you're not using an alternator, the battery should be connected and fully charged.
- The engine MUST be equipped with at least one ground strap to the chassis.

Installing Mallory SparkMap Software and programming the module for first use.

Install the Mallory SparkMap software from the CD included in the kit. Connect the included serial communication cable to your PC. It may be necessary to use a USB to serial adapter if your PC is not equipped with a serial port. Turn the ignition key on and select "Online to Firestorm". If you are using a USB to serial adapter, you will need to determine which port your computer is using for your adapter. This can be found in your PC device manager under "Ports". Device manager can be found under My Computer / Properties. The details of how to access it can vary slightly depending on your operating system. If you need assistance with this, contact the MALLORY Technical Service Department at 216-688-8300 Monday through Friday, 8:00 am to 5:00 pm Eastern Time.

Help for any parameter in the Mallory SparkMap software, can be accessed by clicking on the parameter name and pressing F1.

Once you are online with the module the "Comm. Rx" light will be flashing on the main screen, and the information bar at the bottom of the screen will display "Online, F9" in the lower left hand corner. Go to the Ignition Configuration Screen (Ctrl-I) and select the Ignition trigger type from the drop down box and press F10 to send the change to the Firestorm Module. This will set all parameters on this screen and save the changes to memory in the Firestorm Module.

Navigate to the Engine Configuration Screen (Ctrl-E) and enable any

sensors you have installed to use as an input to Firestorm. These may include:

MAP -manifold pressure sensor
TPS- throttle position sensor
ECT - engine coolant temp sensor
IAT- intake air temp sensor
HEGO - wideband a/f ratio sensor
Set rev limits based on your application requirements.

If Firestorm fan control is used, set fan on and off temps based on your application requirements.

Press "**Send all to ECM**" to save changes to the Firestorm module.

Press F3 to navigate to the Base ignition advance table. This table is where ignition timing tuning for maximum performance is done. This map is pre loaded with values that are a good starting point. Changes to this table should be made to achieve maximum torque on an engine / chassis dyno, or maximum speed on the track without detonation, and under controlled conditions. If you are not comfortable or familiar with the tuning process, contact Mallory Technical Service for a recommendation to an authorized Mallory tuning dealer in your area.

TROUBLESHOOTING

This section offers several tests and checks you can perform to ensure proper installation and operation of the Firestorm Ignition Control Module. If you experience a problem with your Firestorm, first check for proper installation and poor connections. You can eliminate many problems by checking these items. If you have any questions concerning your Firestorm Ignition Control Module contact the MALLORY Technical Service Department at 216-688-8300 Monday through Friday, 8:00 am to 5:00 pm Eastern time.

Misses and Intermittent Problems

Most common causes include a coil or plug wire failure and arcing from the boot plug. Perform the following checks:

- Inspect the plug wires at the coil and at the spark plug for a tight connection. Visually inspect for cuts, abrasions, or burns.
- Inspect the primary coil wire connections. WARNING: During cranking, or while the engine is running, very high voltage will be present and no test equipment should be connected. WARNING: Do not touch the coil terminals during cranking or while the engine is running.
- Make sure that the battery is fully charged and the connections are clean and tight. If you are not running an alternator, this is an imperative check. If the battery voltage drops below 10 volts during a race, it can start to affect the Ignition Control Module operations.
- Is the engine running lean? Inspect the spark plugs and the entire fuel system.
- Check all wiring connections for corrosion or damage. Remember to use proper connections followed by soldering, then seal the connections completely.

Checking for Spark

Verify that the LED lights on the front of the Firestorm module blink during cranking. Due to the high voltage output of the coil, it is recommended to verify spark using a timing light during cranking. If the light flashes during cranking then current is being sent to the spark plug by the module.

If you encounter problems or if you need further technical assistance, please call our technical service line at (216)688-8300.

69100SR - MULTI COIL

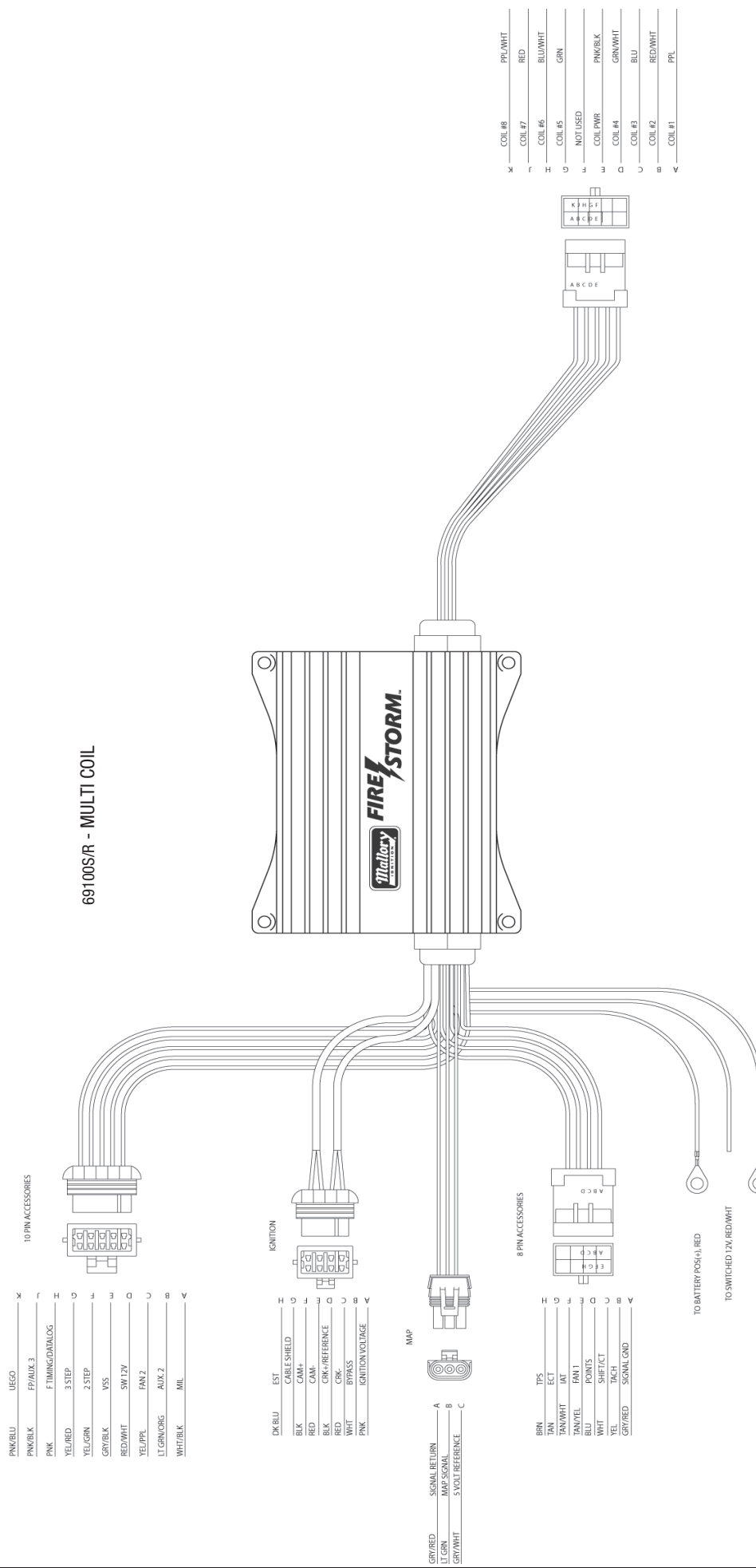

10 PIN ACCESSORIES		
X	PNK/BLU	UEGO
Y	PNK/BLK	FP/AUX.3
Z	PNK	F TIMING/DIAGNOS
A	YEL/RED	3 STEP
B	YEL/GRN	2-STEP
C	GRY/BLK	VSS
D	RED/WHI	SW12V
E	YEL/APP	IFAN.2
F	LT GRN/ORG	AUX.2
G	WHI/BLK	MIL
H		
I		
J		
K		
L		
M		
N		
O		
P		
Q		
R		
S		
T		
U		
V		

IGNITION		
H	DK/BLU	EST
I	BLK	CABLE SHIELD
J	RED	CAM+
K	BLK	CAM-
L	RED	CRK/REFERENCE
M	WHI	CRK
N	PNK	BYPASS
O		IGNITION VOLTAGE
P		
Q		
R		
S		
T		
U		
V		

MAP		
A	GRY/RED	SIGNAL RETURN
B	LT GRN	MAP SIGNAL
C	GRY/WHI	SVOLT REFERENCE

8 PIN ACCESSORIES		
H	BRN	TPS
I	TAN	ECT
J	TAN/WHI	IAT
K	TAN/TEL	FAN.1
L	BLU	POINTS
M	WHI	SHIF/CT
N	YEL	TACH
O	GRY/RED	SIGNAL GND
P		
Q		
R		
S		
T		
U		
V		

TO BATTERY POS(+), RED
TO SWITCHED 12V, RED/WHI

X	COIL #8	PP/WHI
Y	COIL #7	RED
Z	COIL #6	BLU/WHI
A	COIL #5	GRN
B	NOT USED	
C	COIL #4R	PNK/BLK
D	COIL #4	GRN/WHI
E	COIL #3	BLU
F	COIL #2	RED/WHI
G	COIL #1	PPL

ACCESSORY HARNESS LAYOUT

PIN	FUNCTION	WIRE COLOR	DESCRIPTION
A	SIGNAL GROUND	GREY/RED	GROUND FOR ECT, IAT, AND TPS SENSORS
B	TACH	YELLOW	OUTPUT FOR TACHOMETER OR CRANK SIGNAL TO FUEL INJECTION ECM
C	SHIFT/CT	WHITE	SHIFT LIGHT GROUND OUTPUT OR CAM TACH OUTPUT CONFIGURE IN SPARKMAP SOFTWARE
D	PTS	BLUE	TRIGGER WIRE, CONNECT TO POINTS OR GEN7/THRUSTER EST OUT
E	FAN 1	TAN/YELLOW	GROUND OUTPUT FOR FAN 1 CONTROL RELAY
F	IAT	TAN/WHITE	INLET AIR TEMP SIGNAL IN FROM SENSOR
G	ECT	TAN	ENGINE COOLANT TEMP SIGNAL IN FROM SENSOR
H	TPS	BROWN	THROTTLE POSITION SENSOR SIGNAL IN

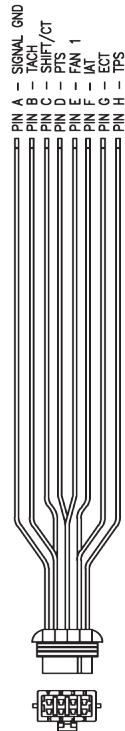

8-PIN
ACCESSORY HARNESS

PIN	FUNCTION	WIRE COLOR	DESCRIPTION
A	MIL	WHITE/BLACK	GROUND TO EXTERNAL MALFUNCTION INDICATOR LAMP
B	AUX. 2	LT. GREEN/ORANGE	GROUND OUTPUT TO CONTROL AUXILIARY RELAY
C	FAN 2	YELLOW/PURPLE	GROUND OUTPUT TO COOLING FAN RELAY
D	SWITCHED 12V OUT	RED/WHITE	12V SW. IGN OUTPUT FOR OPTIONAL ACCESSORY
E	VSS	GREY/BLACK	SIGNAL INPUT FROM VEHICLE SPEED SENSOR
F	2 STEP	YELLOW/GREEN	APPLY 12V TO ENABLE 2 STEP REV LIMITER
G	3 STEP	YELLOW/RED	APPLY 12V TO ENABLE 3 STEP REV LIMITER
H	F TIMING/DATALOG	PINK	GROUND TO ENABLE INTERNAL DATALOGGING OR FORCE TIMING
J	FP/AUX 3	PINK/BLACK	GROUND OUTPUT TO FUEL PUMP OR OTHER OPTIONAL RELAY
K	UEGO	PINK/BLUE	TO WIDEBAND SIGNAL INPUT - REFER TO INSTRUCTIONS FOR YOUR SPECIFIC WIDEBAND

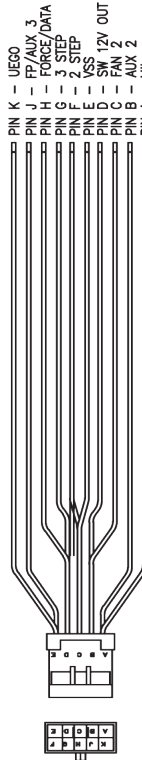

10-PIN
ACCESSORY HARNESS



MALLORY IGNITION IS A TRADEMARK OF PRESTOLITE PERFORMANCE
 10601 Memphis Ave. #12, Cleveland, OH 44144
 216.688.8300 FAX 216.688.8306

FORM 69100S/R
 06/12
 Made in U.S.A.
 Printed in U.S.A.